

Model Name: P215HVN01.0

Issue Date : 2017/7/20

() Preliminary Specifications

(*) Final Specifications

Contents

1. General Description 5

1.1. Display Characteristics 5

1.2. Optical Characteristics..... 6

1.3. Mechanical Characteristics..... 11

2. Absolute Maximum Ratings 14

3. Electrical Specification 15

3.1. Block Diagram 15

Customer Signature	Date	AUO	Date
Approved By _____		Approval By PM Director Jacky Su _____	
Note		Reviewed By RD Director Eugene CC Chen _____	
		Reviewed By Project Leader Bata Lin _____	
		Prepared By PM YuHua YH Wu _____	

3.2. Interface Connection 16

3.3. Electrical Characteristics 18

3.4. Signal Characteristics..... 19

3.5. Power ON/OFF Sequence..... 25

4.	Backlight Unit	26
4.1.	Block Diagram	26
4.2.	Interface Connection	27
4.3.	Electrical Characteristics	30
5.	Reliability Test Items	32
6.	International Standard	33
6.1.	Safety	33
6.2.	EMC	33
7.	Packing	34
7.1.	Definition of Label	34
7.2.	Packing Methods	35
7.3.	Pallet and Shipment Information	36
8.	Precautions	37
8.1.	Mounting Precautions	37
8.2.	Operating Precautions	37
8.3.	Operating Condition for Public Information Display	37
8.4.	Electrostatic Discharge Control	38
8.5.	Precautions for Strong Light Exposure	38
8.6.	Storage	38
8.7.	Handling Precautions for Protection Film	39

Record of Revision

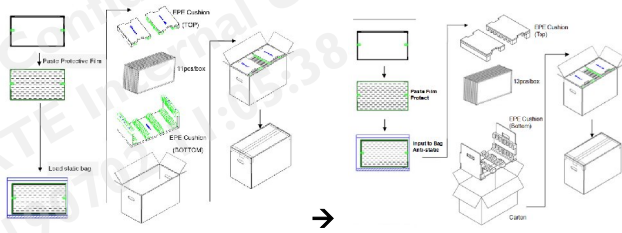
Version	Date	Page	Description																																																																																				
0.1	2015/11/16	24	Power Sequence Timing update(T6)																																																																																				
0.2	2015/12/01		Format updated																																																																																				
		5	Operation temp: 0~50 oC→-10~50 oC																																																																																				
		10	Update dimension depth(max), depth(min) information																																																																																				
		33	Shipping Label format update																																																																																				
1.0	2016/1/29	37	Update 8.3 (2)																																																																																				
1.1	2016/08/05	26	Modify BLU Connector dimension																																																																																				
1.2	2017/07/20	34	7.2 Packing Methods change. 																																																																																				
1.2	2017/07/20	35	7.3 Pallet and Shipment Information: Cushion, Box, Packing Box, Pallet, Pallet after Packing dimension and weight change. <table border="1" data-bbox="592 1134 941 1333"> <thead> <tr> <th>Item</th> <th>Q'ty</th> <th>Specification</th> <th>Dimension</th> <th>Weight(kg)</th> <th>Remark</th> </tr> </thead> <tbody> <tr> <td>Panel</td> <td>1</td> <td></td> <td>495.0(±0.1)mm x 292.2(±0.1)mm x 10.6(±0.1)mm</td> <td>1.67</td> <td>None</td> </tr> <tr> <td>Cushion</td> <td>1</td> <td></td> <td></td> <td>0.35</td> <td></td> </tr> <tr> <td>Box</td> <td>1</td> <td></td> <td>585(±0.1)mm x 375(±0.1)mm x 37.5(±0.1)mm</td> <td>0.35</td> <td>without Panel & cushion</td> </tr> <tr> <td>Packing Box</td> <td>1</td> <td></td> <td>585(±0.1)mm x 375(±0.1)mm x 37.5(±0.1)mm</td> <td>0.35</td> <td>with panel & cushion</td> </tr> <tr> <td>Pallet</td> <td>1</td> <td></td> <td>1150(±0.1)mm x 1150(±0.1)mm x 132(±0.1)mm</td> <td>22.1</td> <td>None</td> </tr> <tr> <td>Pallet after Packing</td> <td>1</td> <td></td> <td>1150(±0.1)mm x 1150(±0.1)mm x 132(±0.1)mm</td> <td>26.5</td> <td>None</td> </tr> </tbody> </table> <table border="1" data-bbox="974 1134 1299 1333"> <thead> <tr> <th>Item</th> <th>Q'ty</th> <th>Specification</th> <th>Dimension</th> <th>Weight(kg)</th> <th>Remark</th> </tr> </thead> <tbody> <tr> <td>Panel</td> <td>1</td> <td></td> <td>495.0(±0.1)mm x 292.2(±0.1)mm x 10.6(±0.1)mm</td> <td>1.67</td> <td></td> </tr> <tr> <td>Cushion</td> <td>1</td> <td></td> <td></td> <td>0.35</td> <td></td> </tr> <tr> <td>Box</td> <td>1</td> <td></td> <td>585(±0.1)mm x 375(±0.1)mm x 37.5(±0.1)mm</td> <td>1.40</td> <td>without Panel</td> </tr> <tr> <td>Packing Box</td> <td>1</td> <td></td> <td>585(±0.1)mm x 375(±0.1)mm x 37.5(±0.1)mm</td> <td>2.86</td> <td>with panel & Box & cushion</td> </tr> <tr> <td>Pallet</td> <td>1</td> <td></td> <td>1150(±0.1)mm x 1150(±0.1)mm x 132(±0.1)mm</td> <td>14.2</td> <td></td> </tr> <tr> <td>Pallet after Packing</td> <td>1</td> <td></td> <td>1150(±0.1)mm x 1150(±0.1)mm x 132(±0.1)mm</td> <td>18.6</td> <td></td> </tr> </tbody> </table>	Item	Q'ty	Specification	Dimension	Weight(kg)	Remark	Panel	1		495.0(±0.1)mm x 292.2(±0.1)mm x 10.6(±0.1)mm	1.67	None	Cushion	1			0.35		Box	1		585(±0.1)mm x 375(±0.1)mm x 37.5(±0.1)mm	0.35	without Panel & cushion	Packing Box	1		585(±0.1)mm x 375(±0.1)mm x 37.5(±0.1)mm	0.35	with panel & cushion	Pallet	1		1150(±0.1)mm x 1150(±0.1)mm x 132(±0.1)mm	22.1	None	Pallet after Packing	1		1150(±0.1)mm x 1150(±0.1)mm x 132(±0.1)mm	26.5	None	Item	Q'ty	Specification	Dimension	Weight(kg)	Remark	Panel	1		495.0(±0.1)mm x 292.2(±0.1)mm x 10.6(±0.1)mm	1.67		Cushion	1			0.35		Box	1		585(±0.1)mm x 375(±0.1)mm x 37.5(±0.1)mm	1.40	without Panel	Packing Box	1		585(±0.1)mm x 375(±0.1)mm x 37.5(±0.1)mm	2.86	with panel & Box & cushion	Pallet	1		1150(±0.1)mm x 1150(±0.1)mm x 132(±0.1)mm	14.2		Pallet after Packing	1		1150(±0.1)mm x 1150(±0.1)mm x 132(±0.1)mm	18.6	
Item	Q'ty	Specification	Dimension	Weight(kg)	Remark																																																																																		
Panel	1		495.0(±0.1)mm x 292.2(±0.1)mm x 10.6(±0.1)mm	1.67	None																																																																																		
Cushion	1			0.35																																																																																			
Box	1		585(±0.1)mm x 375(±0.1)mm x 37.5(±0.1)mm	0.35	without Panel & cushion																																																																																		
Packing Box	1		585(±0.1)mm x 375(±0.1)mm x 37.5(±0.1)mm	0.35	with panel & cushion																																																																																		
Pallet	1		1150(±0.1)mm x 1150(±0.1)mm x 132(±0.1)mm	22.1	None																																																																																		
Pallet after Packing	1		1150(±0.1)mm x 1150(±0.1)mm x 132(±0.1)mm	26.5	None																																																																																		
Item	Q'ty	Specification	Dimension	Weight(kg)	Remark																																																																																		
Panel	1		495.0(±0.1)mm x 292.2(±0.1)mm x 10.6(±0.1)mm	1.67																																																																																			
Cushion	1			0.35																																																																																			
Box	1		585(±0.1)mm x 375(±0.1)mm x 37.5(±0.1)mm	1.40	without Panel																																																																																		
Packing Box	1		585(±0.1)mm x 375(±0.1)mm x 37.5(±0.1)mm	2.86	with panel & Box & cushion																																																																																		
Pallet	1		1150(±0.1)mm x 1150(±0.1)mm x 132(±0.1)mm	14.2																																																																																			
Pallet after Packing	1		1150(±0.1)mm x 1150(±0.1)mm x 132(±0.1)mm	18.6																																																																																			

1. General Description

This specification applies to the 21.5 inch wide Color a-Si TFT-LCD Module P215HVN01.0. The display supports the Full HD - 1920(H) x 1080(V) screen format and 16.7M colors (8 bits RGB data input). The input interface is Dual channel LVDS and this module doesn't contain a driver board for backlights.

* General Information

1.1. Display Characteristics

The following items are characteristics summary on the table under 25°C condition:

ITEMS	Unit	SPECIFICATIONS
Screen Diagonal	[mm]	546.86(21.5")
Active Area	[mm]	476.64 (H) x 268.11 (V)
Pixels H x V	-	1920(x3) x 1080
Pixel Pitch	[um]	248.25 (per one triad) ×248.25
Pixel Arrangement	-	R.G.B. Vertical Stripe
Display Mode	-	VA Mode, Normally Black
White Luminance (Center)	[cd/m2]	300 (Typ.)
Contrast Ratio	-	3000 (Typ.)
Response Time	[msec]	18ms (Typ., on/off)at surface 35 degree C
Power Consumption (LCD Module + Backligh unit)	[Watt]	15.2 (Typ.) LCD module : PDD (Typ.)= 3.1 @ all white pattern,Fv=60Hz Backlight unit : PBLU (Typ.) =12.1 @Is=65mA
Weight	[Grams]	1670
Outline Dimension	[mm]	495.6(H) × 292.2(V) × 10.6(D) Typ.
Electrical Interface	-	Dual channel LVDS , 8 bits RGB data input
Support Color	-	16.7M colors
Surface Treatment	-	Anti-Glare, 3H
Temperature Range		
Operating	[oC]	-10 to +50
Storage (Shipping)	[oC]	-20 to +60
RoHS Compliance	-	RoHS Compliance
TCO Compliance	-	TCO 6.0 Compliance

1.2. Optical Characteristics

The optical characteristics are measured on the following test condition.

Test Condition:

1. Equipment setup: Please refer to Note 1-1.
2. Panel Lighting time: 30 minutes
3. VDD=5.0V, Fv=60Hz, Is=65mA, Ta=25°C

Symbol	Description		Min.	Typ.	Max.	Unit	Remark
Lw	White Luminance (Center of screen)		240	300	-	[cd/m ²]	Note 1-1 By SR-3
Luni	Luminance Uniformity (9 points)		75	80	-	[%]	Note 1-2 By SR-3
CR	Contrast Ratio (Center of screen)		2000	3000	-	-	Note 1-3 By SR-3
θR	Horizontal Viewing Angle (CR=10)	Right	75	89	-	[degree]	Note 1-4 By SR-3
θL		Left	75	89	-		
ΦH	Vertical Viewing Angle (CR=10)	Up	75	89	-		
ΦL		Down	75	89	-		
θR	Horizontal Viewing Angle (CR=5)	Right	75	89	-		
θL		Left	75	89	-		
ΦH	Vertical Viewing Angle (CR=5)	Up	75	89	-		
ΦL		Down	75	89	-		
TR	Response Time	Rising Time	-	13	28	[msec]	Note 1-5 By TRD-100
TF		Falling Time	-	5	8		
-		Rising + Falling	-	18	36		
Rx	Color Coordinates (CIE 1931)	Red x	0.622	0.652	0.682	-	By SR-3
Ry		Red y	0.305	0.335	0.365		
Gx		Green x	0.291	0.321	0.351		
Gy		Green y	0.595	0.625	0.655		
Bx		Blue x	0.123	0.153	0.183		
By		Blue y	0.037	0.067	0.097		
Wx		White x	0.283	0.313	0.343		
Wy		White y	0.299	0.329	0.359		
NTSC Area Ratio				72		[%]	By SR-3
CT	Crosstalk		-	-	2.0	[%]	Note 1-6 By SR-3

FdB	Flicker (Center of screen)	-	-	-20	[dB]	Note 1-7 By SR-3
-----	----------------------------	---	---	-----	------	---------------------

Note 1-1: Equipment setup :

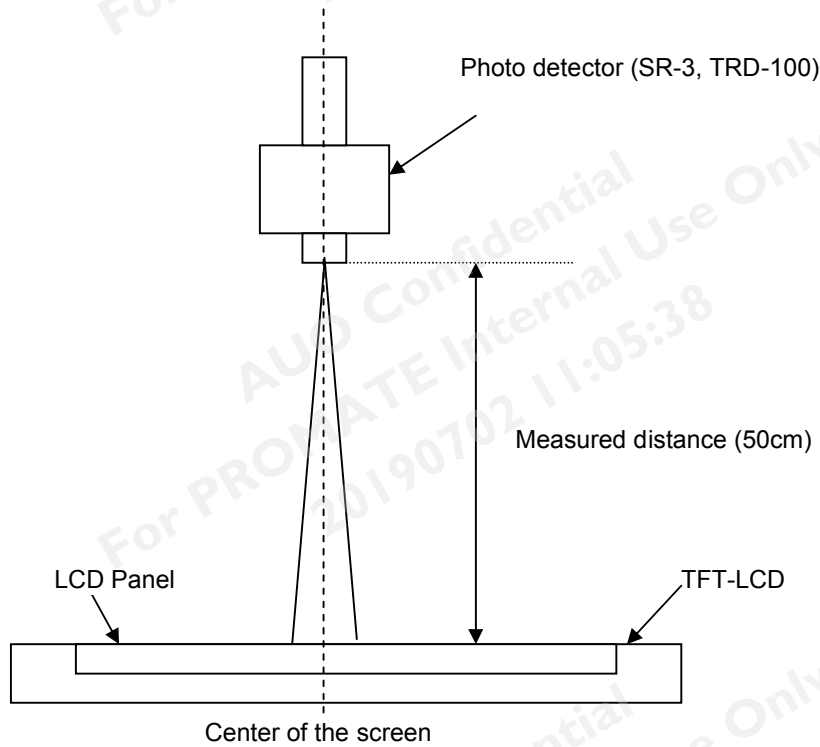

Note 1-2: Luminance Uniformity Measurement

Definition:

$$\text{Luminance Uniformity} = \frac{\text{Minimum Luminance of 9 Points (P1 ~ P9)}}{\text{Maximum Luminance of 9 Points (P1 ~ P9)}}$$

- a. Test pattern: White Pattern

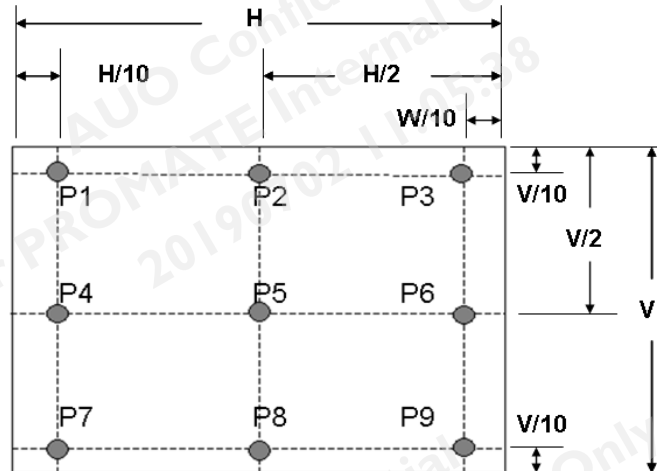

Note 1-3: Contrast Ratio Measurement

Definition:

$$\text{Contrast Ratio} = \frac{\text{Luminance of White pattern}}{\text{Luminance of Black pattern}}$$

- a. Measured position: Center of screen (P5) & perpendicular to the screen ($\theta = \Phi = 0^\circ$)

Note 1-4: Viewing angle measurement

Definition: The angle at which the contrast ratio is greater than 10 & 5 .

- a. Horizontal view angle: Divide to left & right (θ_L & θ_R)

Vertical view angle: Divide to up & down (Φ_H & Φ_L)

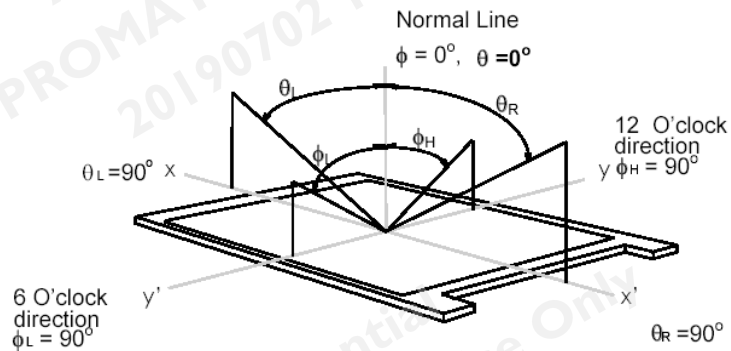

Note 1-5: Response time measurement

The output signals of photo detector are measured when the input signals are changed from “Black” to “White” (rising time, TR), and from “White” to “Black” (falling time, TF), respectively. The response time is interval between the 10% and 90% of optical response. (Black & White color definition: Please refer section 3.4.3)

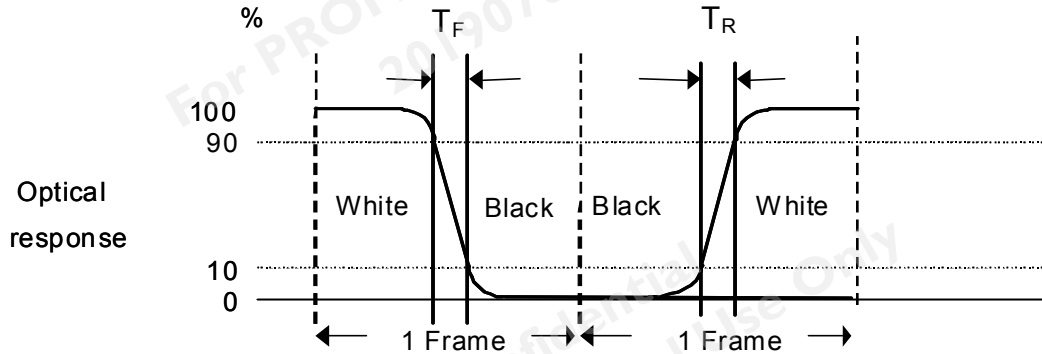

Note 1-6: Crosstalk measurement

Definition:

CT = Max. (CTH,CTV);

Where

a. Maximum Horizontal Crosstalk :

$$CTH = \text{Max.} (| YBL - YAL | / YAL \times 100 \% , | YBR - YAR | / YAR \times 100 \%);$$

Maximum Vertical Crosstalk:

$$CTV = \text{Max.} (| YBU - YAU | / YAU \times 100 \% , | YBD - YAD | / YAD \times 100 \%);$$

b. YAU, YAD, YAL, YAR = Luminance of measured location without Black pattern

YBU, YBD, YBL, YBR = Luminance of measured location with Black pattern

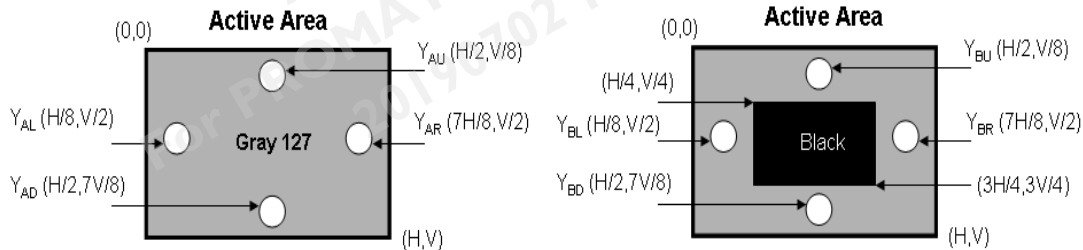

Note 1-7: Flicker measurement

a. Test pattern: It is listed as following.

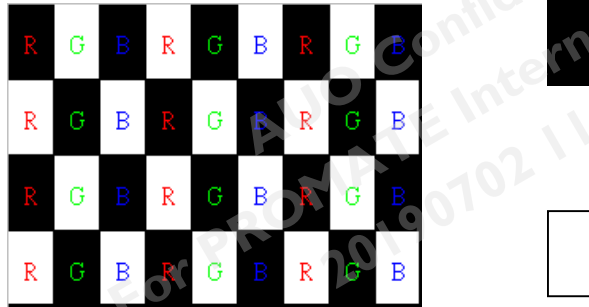

R: Red, G: Green, B: Blue

b. Measured position: Center of screen (P5) & perpendicular to the screen ($\theta=\Phi=0^\circ$)

1.3. Mechanical Characteristics

The contents provide general mechanical characteristics for the model PXXXXXXX.X In addition the figures in the next page are detailed mechanical drawing of the LCD.

Item	Dimension	Unit	Note	
Outline Dimension	Horizontal	495.6	mm	
	Vertical	292.2	mm	
	Depth (Dmin)	7.4	mm	front bezel to back bezel
	Depth (Dmax)	10.6	mm	to wall mount
Weight	1670	G		

1.3.1. Placement Suggestions

1. Landscape Mode: The default placement is T-Con Side on the lower side and the image is shown upright via viewing from the front.
2. Portrait Mode: The default placement is that T-Con side has to be placed on the left side via viewing from the front.

Landscape (Front view)

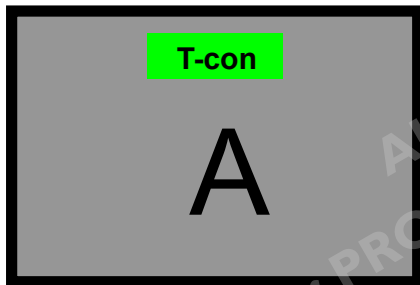

Portrait (Front view)

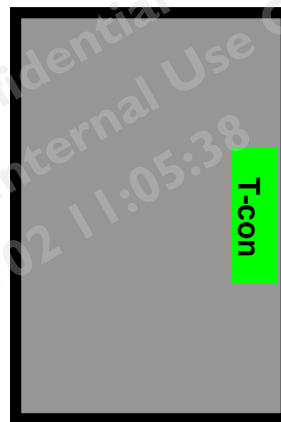

Front View

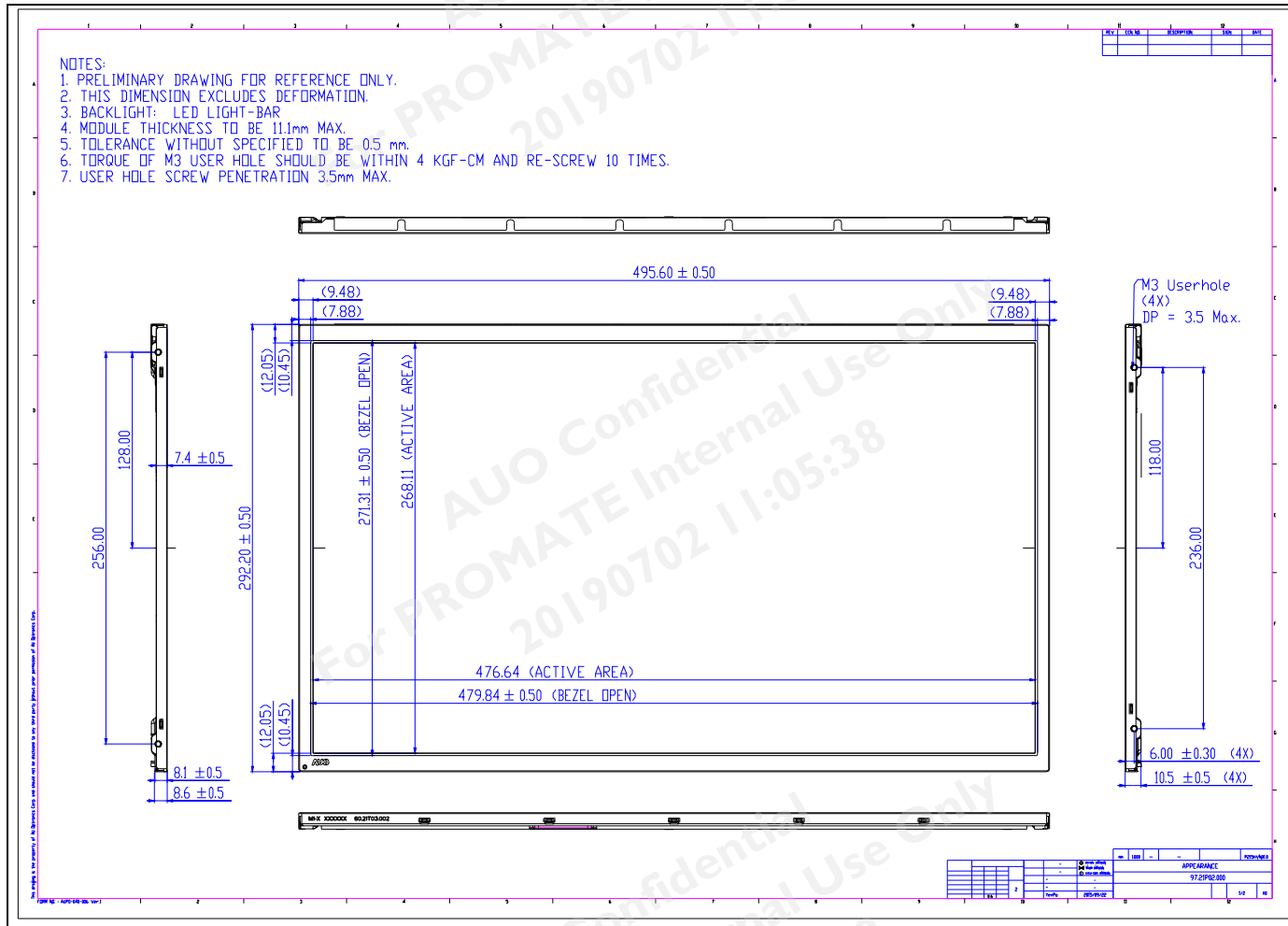

Back View

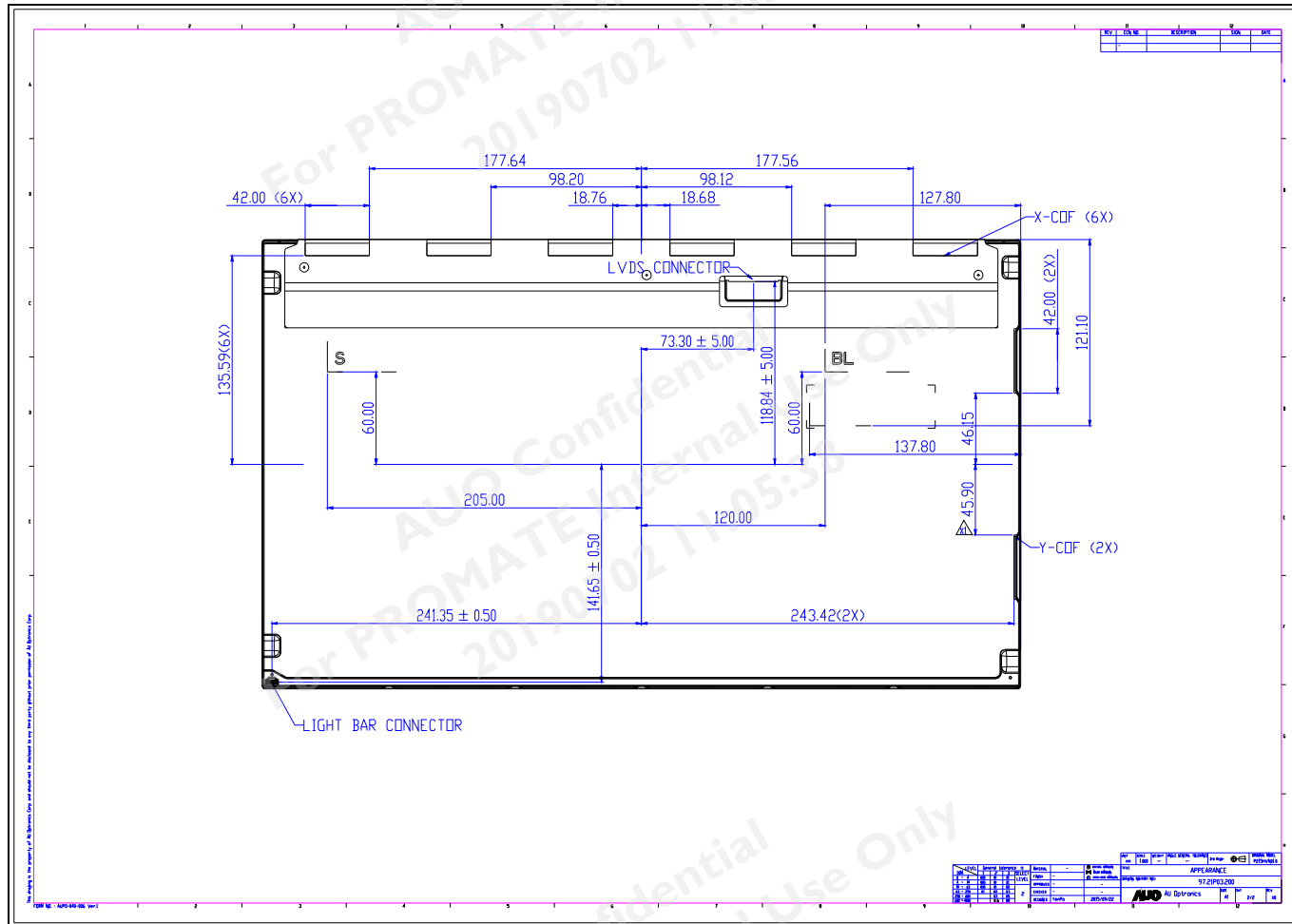

2. Absolute Maximum Ratings

The followings are maximum values which, if exceeded, may cause faulty operation or damage to the unit
Permanent damage may occur if exceeding the following maximum rating.

Symbol	Description	Min.	Max.	Unit	Remark
TOP	Operating Temperature	-10	+50	[°C]	Note 2-1
TGS	Glass surface temperature (operation)	0	+65	[°C]	Note 2-1 Function judged only
HOP	Operation Humidity	5	90	[%RH]	Note 2-1
TST	Storage Temperature	-20	+60	[°C]	
HST	Storage Humidity	5	90	[%RH]	

Note 2-1: Temperature and relative humidity range are shown as the below figure.

1. 90% RH Max ($T_a \leq 39^\circ\text{C}$)
2. Max wet-bulb temperature at 39°C or less. ($T_a \leq 39^\circ\text{C}$)
3. No condensation

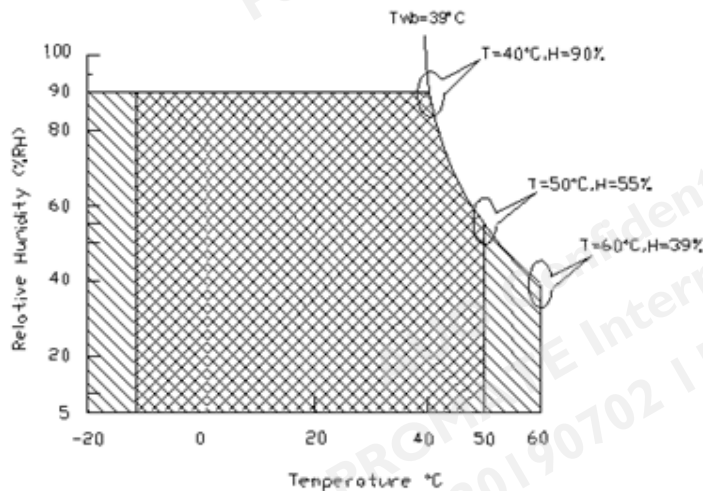

Operating Range



Storage Range

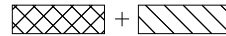

3. Electrical Specification

The P215HVN01.0 requires two power inputs. One is employed to power the LCD electronics and to drive the TFT array and liquid crystal. The other is to power Back Light Unit.

3.1. Block Diagram

The following shows the block diagram of the 21.5 inch Color TFT-LCD Module.

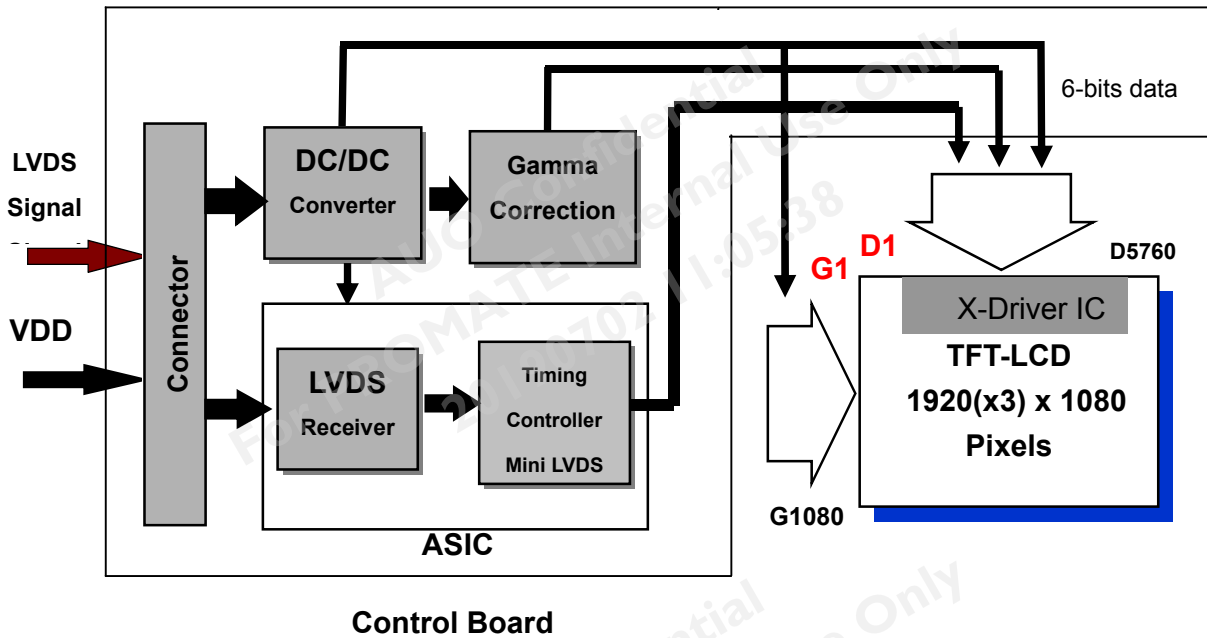

3.2. Interface Connection

3.2.1. Connector Type

TFT-LCD Connector	Manufacturer	P-TWO	STM
	Part Number	AL230F-A0G1D-P	MSCKT2407P30HB
Mating Connector	Manufacturer	JAE	
	Part Number	FI-X30HL (Locked Type)	

3.2.2. Connector Pin Assignment

PIN #	Symbol	Description	Remark
1	RxO0-	Negative LVDS differential data input (Odd data)	
2	RxO0+	Positive LVDS differential data input (Odd data)	
3	RxO1-	Negative LVDS differential data input (Odd data)	
4	RxO1+	Positive LVDS differential data input (Odd data)	
5	RxO2-	Negative LVDS differential data input (Odd data)	
6	RxO2+	Positive LVDS differential data input (Odd data)	
7	GND	Ground	
8	RxOCLK-	Negative LVDS differential clock input (Odd clock)	
9	RxOCLK+	Positive LVDS differential clock input (Odd clock)	
10	RxO3-	Negative LVDS differential data input (Odd data)	
11	RxO3+	Positive LVDS differential data input (Odd data)	
12	RxE0-	Negative LVDS differential data input (Even data)	
13	RxE0+	Positive LVDS differential data input (Even data)	
14	GND	Ground	
15	RxE1-	Negative LVDS differential data input (Even data)	
16	RxE1+	Positive LVDS differential data input (Even data)	
17	GND	Ground	
18	RxE2-	Negative LVDS differential data input (Even data)	
19	RxE2+	Positive LVDS differential data input (Even data)	
20	RxECLK-	Negative LVDS differential clock input (Even clock)	
21	RxECLK+	Positive LVDS differential clock input (Even clock)	
22	RxE3-	Negative LVDS differential data input (Even data)	
23	RxE3+	Positive LVDS differential data input (Even data)	
24	GND	Ground	
25	NC	No connection (for AUO test only. Do not connect)	
26	NC	No connection (for AUO test only. Do not connect)	
27	NC	No connection (for AUO test only. Do not connect)	
28	VDD	Power Supply Input Voltage	
29	VDD	Power Supply Input Voltage	
30	VDD	Power Supply Input Voltage	

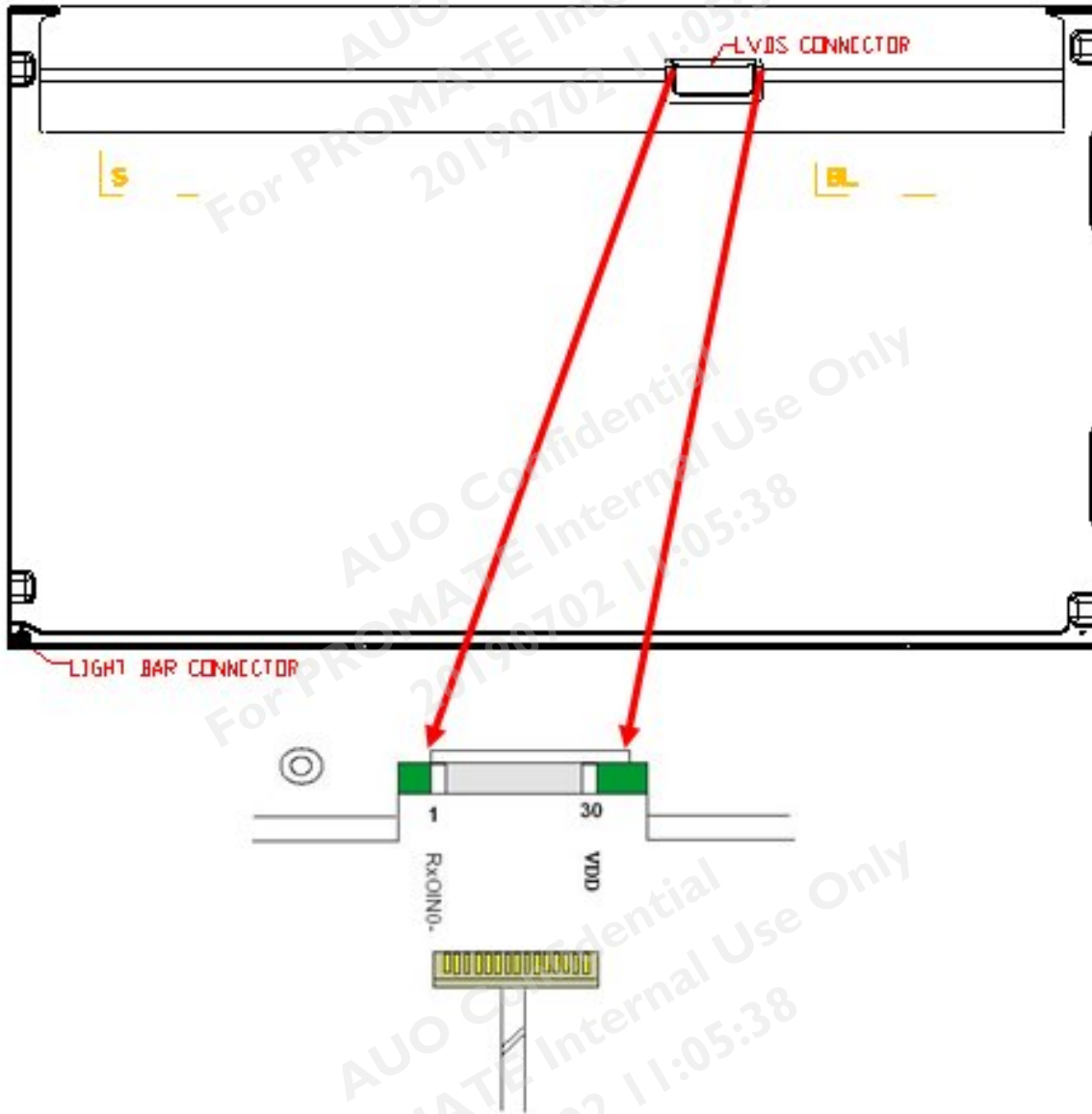

3.3. Electrical Characteristics

3.3.1. Absolute Maximum Rating

Permanent damage may occur if exceeding the following maximum rating.

Symbol	Description	Min	Max	Unit	Remark
VDD	Power Supply Input Voltage	GND-0.3	6.0	[Volt]	Ta=25°C

3.3.2. Recommended Operating Condition

Symbol	Description	Min	Typ	Max	Unit	Remark
VDD	Power supply Input voltage	4.5	5.0	5.5	[Volt]	
IDD	Power supply Input Current (RMS)	-	0.62	0.74	[A]	VDD= 5.0V, All white Pattern, Fv=60Hz
			0.7	0.84	[A]	VDD= 5.0V, All white Pattern, Fv=75Hz
PDD	VDD PowerVDD Power Consumption	-	3.1	3.7	[Watt]	VDD= 5.0V, All white Pattern, Fv=60Hz
			3.5	4.2	[Watt]	VDD= 5.0V, All white Pattern, Fv=75Hz
IRush	Inrush Current	-	-	3.0	[A]	Note 3-1
VDDrp	Allowable VDD Ripple Voltage	-	-	500	[mV]	VDD= 5.0V, All white Pattern, Fv=75Hz

Note 3-1: Inrush Current measurement:

Test circuit:

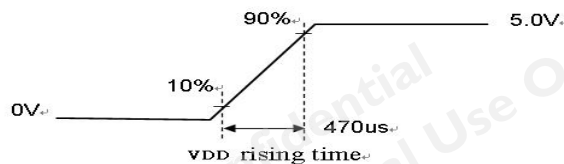
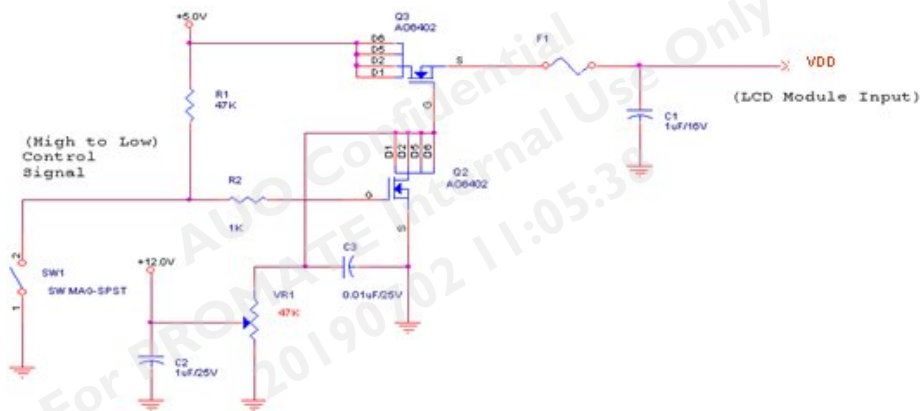

The duration of VDD rising time: 470us.

3.4. Signal Characteristics

3.4.1. LCD Pixel Format

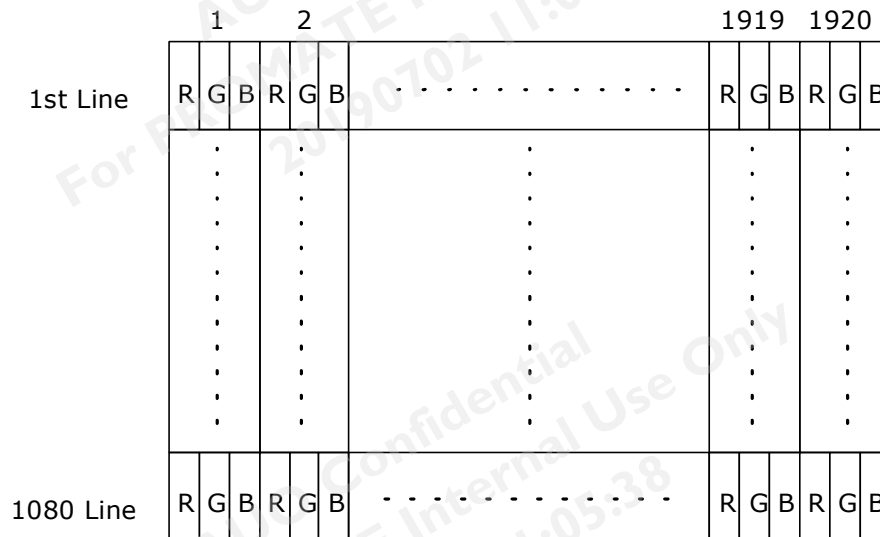

3.4.2. LVDS Data Format

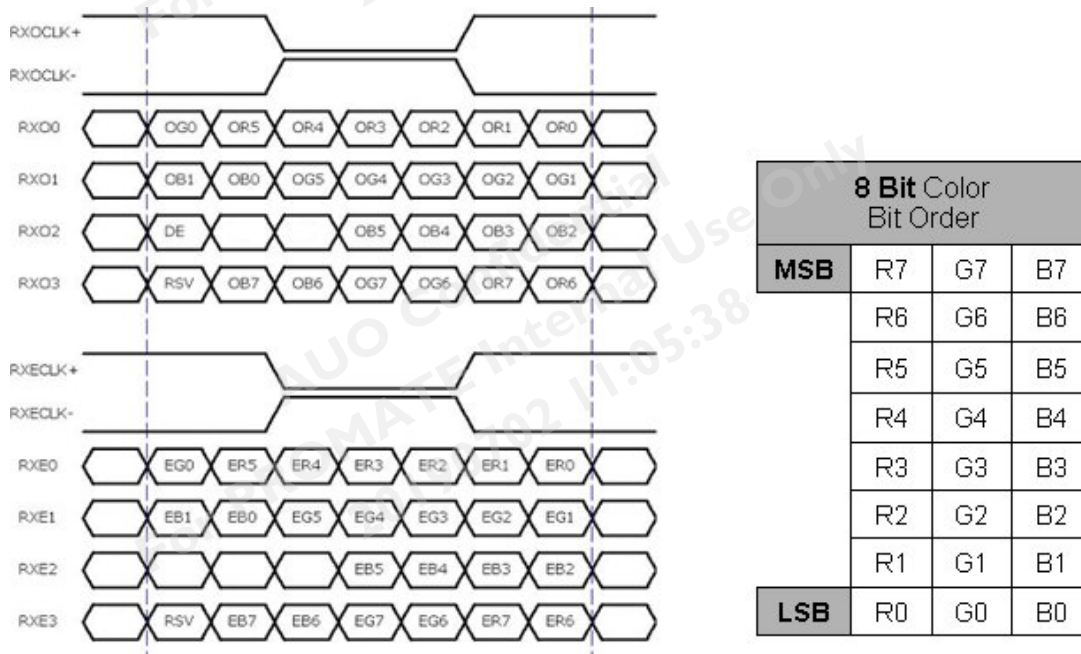

Note 3-2:

- a. O = "Odd Pixel Data" E = "Even Pixel Data"
- b. Refer to 3.4.1 LCD pixel format, the 1st data is 1 (Odd Pixel Data), the 2nd data is 2 (Even Pixel Data) and the last data is 1920 (Even Pixel Data).

3.4.3. Color versus Input Data

The following table is for color versus input data (8bit). The higher the gray level, the brighter the color.

Color	Gray Level	Color Input Data																								Remark
		RED data (MSB:R7, LSB:R0)								GREEN data (MSB:G7, LSB:G0)								BLUE data (MSB:B7, LSB:B0)								
		R7	R6	R5	R4	R3	R2	R1	R0	G7	G6	G5	G4	G3	G2	G1	G0	B7	B6	B5	B4	B3	B2	B1	B0	
Black	-	0	0	0	0	0	0	0	0	0	0	0	0	0	0	0	0	0	0	0	0	0	0	0	0	
White	-	1	1	1	1	1	1	1	1	1	1	1	1	1	1	1	1	1	1	1	1	1	1	1	1	
Gray 127	-	0	1	1	1	1	1	1	1	0	1	1	1	1	1	1	1	0	1	1	1	1	1	1	1	
Red	L0	0	0	0	0	0	0	0	0	0	0	0	0	0	0	0	0	0	0	0	0	0	0	0	0	Black
	:	:	:	:	:	:	:	:	:	:	:	:	:	:	:	:	:	:	:	:	:	:	:	:	:	
	L255	1	1	1	1	1	1	1	1	0	0	0	0	0	0	0	0	0	0	0	0	0	0	0	0	
Green	L0	0	0	0	0	0	0	0	0	0	0	0	0	0	0	0	0	0	0	0	0	0	0	0	0	Black
	:	:	:	:	:	:	:	:	:	:	:	:	:	:	:	:	:	:	:	:	:	:	:	:	:	
	L255	0	0	0	0	0	0	0	0	1	1	1	1	1	1	1	1	0	0	0	0	0	0	0	0	
Blue	L0	0	0	0	0	0	0	0	0	0	0	0	0	0	0	0	0	0	0	0	0	0	0	0	0	Black
	:	:	:	:	:	:	:	:	:	:	:	:	:	:	:	:	:	:	:	:	:	:	:	:	:	
	L255	0	0	0	0	0	0	0	0	0	0	0	0	0	0	0	0	1	1	1	1	1	1	1	1	

3.4.4. LVDS Specification

a. DC Characteristics:

Symbol	Description	Min	Typ	Max	Units	Condition
VTH	LVDS Differential Input High Threshold	-	-	+100	[mV]	VCM = 1.2V
VTL	LVDS Differential Input Low Threshold	-100	-	-	[mV]	VCM = 1.2V
VID	LVDS Differential Input Voltage	100	-	600	[mV]	
VCM	LVDS Common Mode Voltage	+1.0	+1.2	+1.5	[V]	VTH-VTL = 200mV

LVDS Signal Waveform:

Use RxOCLK- & RxOCLK+ as example.

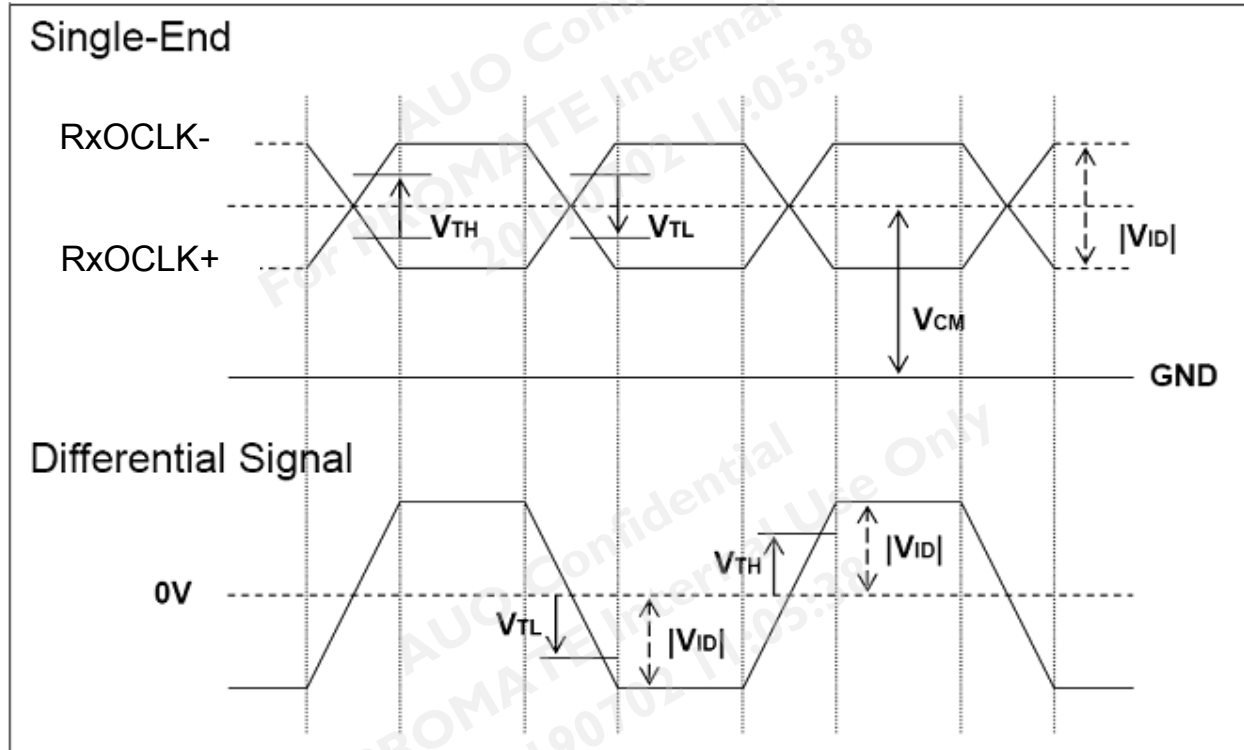

b. AC Characteristics:

Symbol	Description	Min	Max	Unit	Remark
FDEV	Maximum deviation of input clock frequency during Spread Spectrum	-	± 3	%	
FMOD	Maximum modulation frequency of input clock during Spread Spectrum	-	200	KHz	

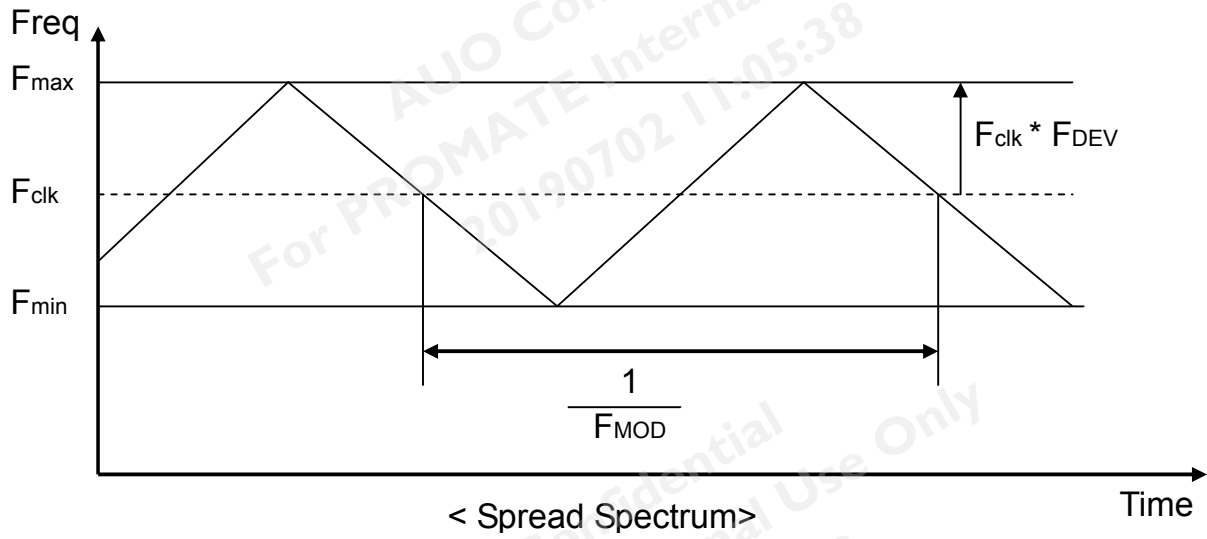

Fclk: LVDS Clock Frequency

3.4.5. Input Timing Specification

It only support DE mode, and the input timing are shown as the following table.

Symbol	Description	Min	Typ	Max	Unit	Remark	
Tv	Vertical Section	Period	1092	1130	1793	Th	Tv
Tdisp (v)		Active	1080	1080	1080	Th	Tdisp (v)
Tblk (v)		Blanking	12	50	713	Th	Tblk (v)
Fv		Frequency	50	60	76	Hz	Fv
Th	Horizontal Section	Period	1004	1050	1100	Tclk	Th
Tdisp (h)		Active	960	960	960	Tclk	Tdisp (h)
Tblk (h)		Blanking	44	90	140	Tclk	Tblk (h)
Fh		Frequency	55	68	90	KHz	Fh
Tclk	LVDS Clock	Period	11.1	14.0	18.2	ns	Tclk
Fclk		Frequency	54.8	71.2	90.0	MHz	Fclk

Note 3-3: The equation is listed as following. Please don't exceed the above recommended value.

$$Fh (\text{Min.}) = Fclk (\text{Min.}) / Th (\text{Min.});$$

$$Fh (\text{Typ.}) = Fclk (\text{Typ.}) / Th (\text{Typ.});$$

$$Fh (\text{Max.}) = Fclk (\text{Max.}) / Th (\text{Min.});$$

Note 3-4: The equation is listed as following. Please don't exceed the above recommended value.

$$Fclk (\text{Min.}) = Fv (\text{Min.}) \times Th (\text{Min.}) \times Tv (\text{Min.});$$

$$Fclk (\text{Typ.}) = Fv (\text{Typ.}) \times Th (\text{Typ.}) \times Tv (\text{Typ.});$$

$$Fclk (\text{Max.}) = Fv (\text{Max.}) \times Th (\text{Typ.}) \times Tv (\text{Typ.});$$

3.4.6. Input Timing Diagram

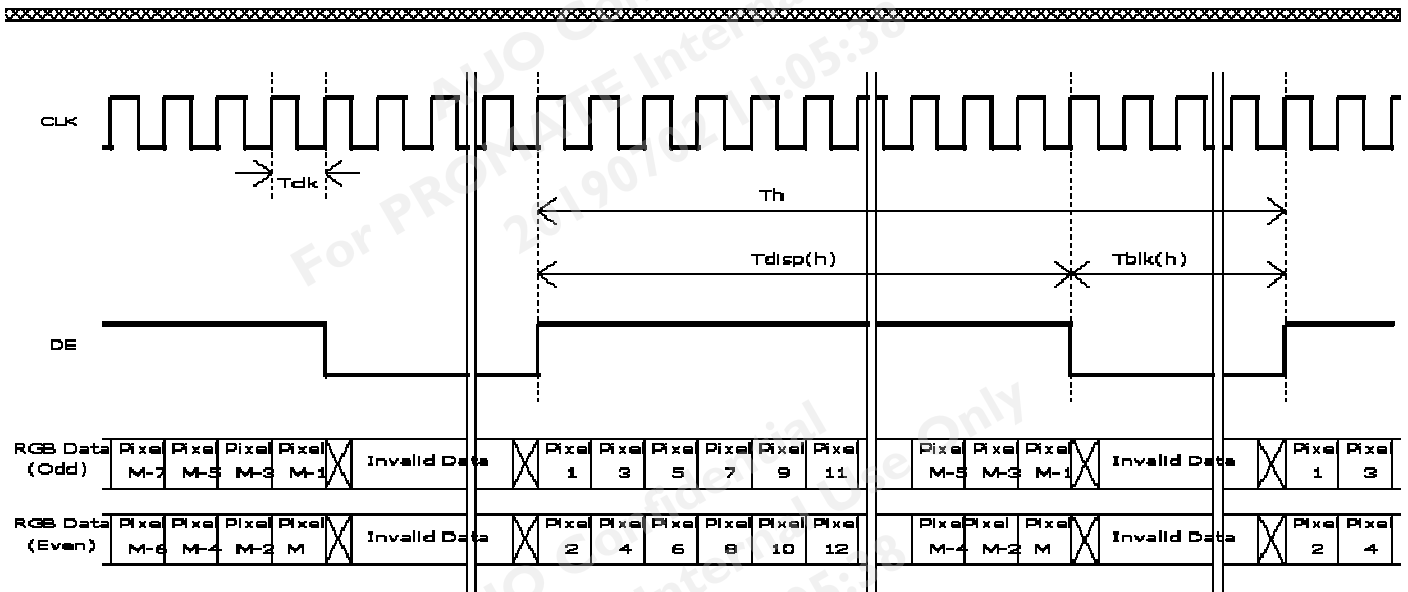
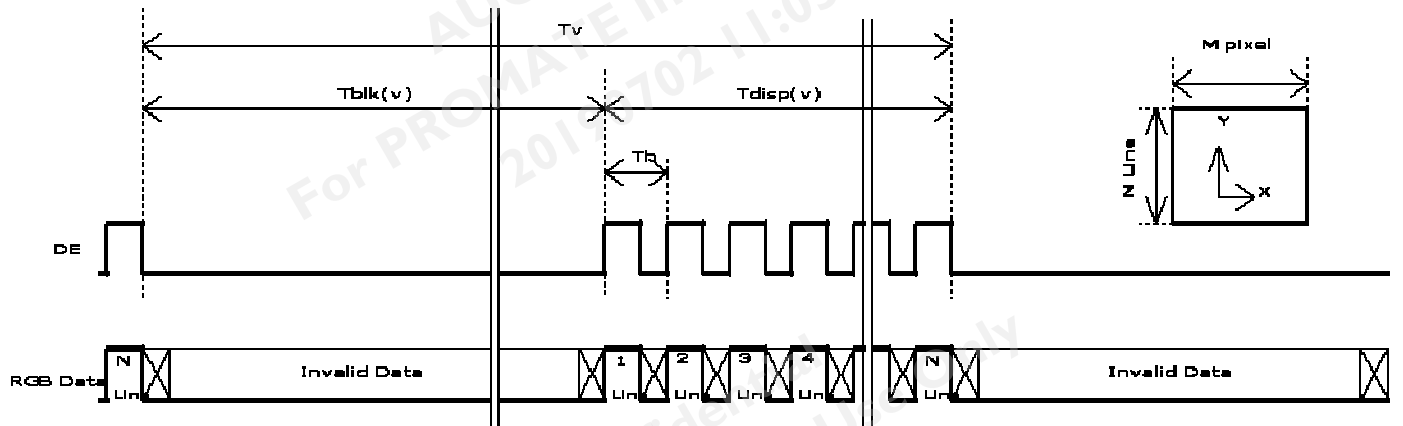

3.5. Power ON/OFF Sequence

VDD power, LVDS signal and backlight on/off sequence are as following. LVDS signals from any system shall be Hi-Z state when VDD is off.

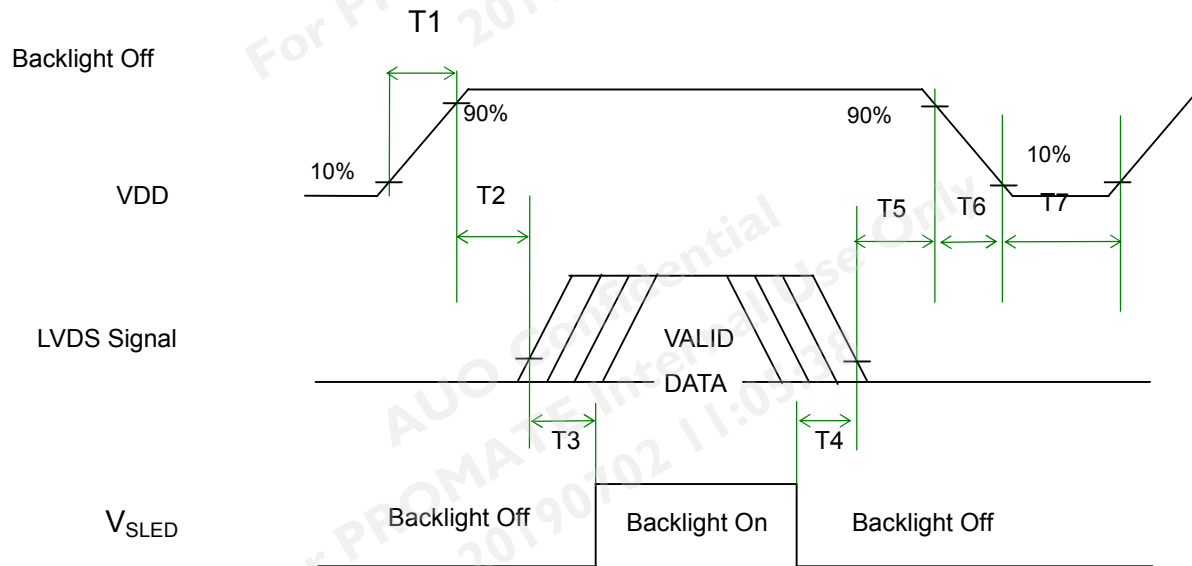

Power Sequence Timing

Symbol	Value			Unit	Remark
	Min.	Typ.	Max.		
T1	0.5	-	10	[ms]	
T2	0	-	50	[ms]	
T3	500	-	-	[ms]	
T4	100	-	-	[ms]	
T5	0	-	50	[ms]	Note 3-5 Note 3-6
T6	0	-	200	[ms]	Note 3-6 Note 3-7
T7	1000	-	-	[ms]	

Note 3-5 : Recommend setting T5 = 0ms to avoid electronic noise when VDD is off.

Note 3-6 : During T5 and T6 period , please keep the level of input LVDS signals with Hi-Z state.

Note 3-7 : Voltage of VDD must decay smoothly after power-off. (customer system decide this value)

4. Backlight Unit

4.1. Block Diagram

The following shows the block diagram of the 21.5 inch Backlight Unit. And it includes 60 pcs LED in the LED light bar. (4 strings and 15 pcs LED of one string).

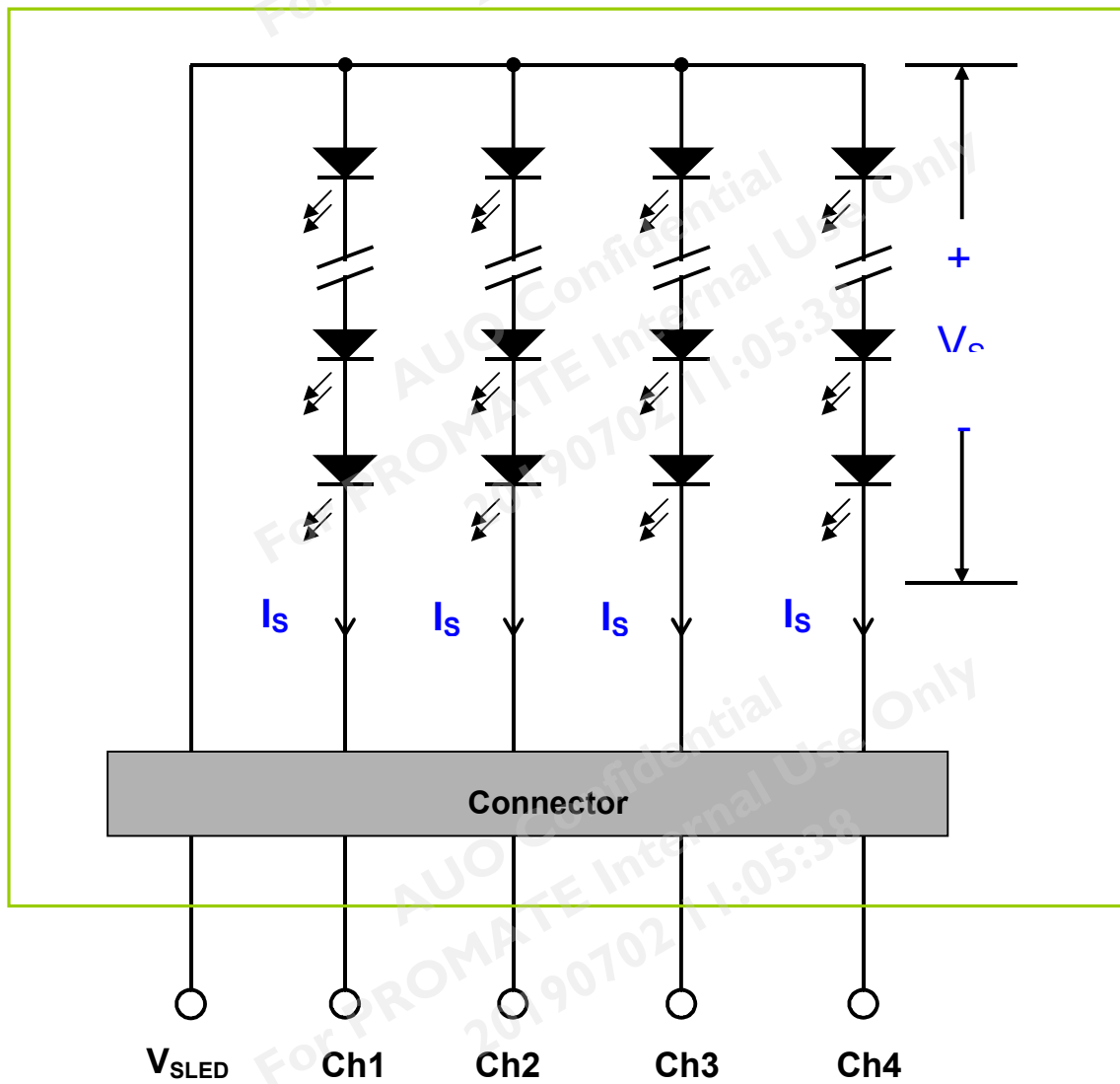

4.2. Interface Connection

4.2.1. Connector Type

Backlight Connector	Manufacturer	ENTERY
	Part Number	3707K-S06N-21R
Mating Connector	Manufacturer	ENTERY
	Part Number	H112K-P06N-00B (Non-Locking type) H112K-P06N-03B (Locking type)

Backlight Connector dimension:

$H \times V \times D = H \times V \times D = 7.9 \times 3.05 \times 4.25$, Pitch = 1.0 (unit = mm)

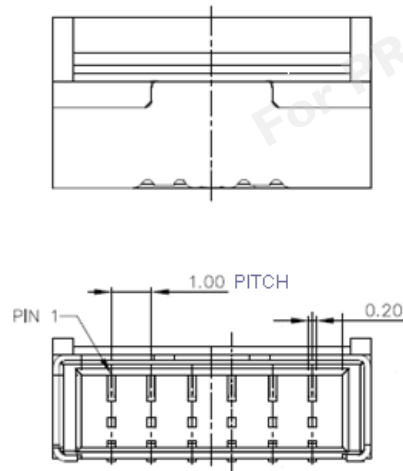

Mating Connector dimension:

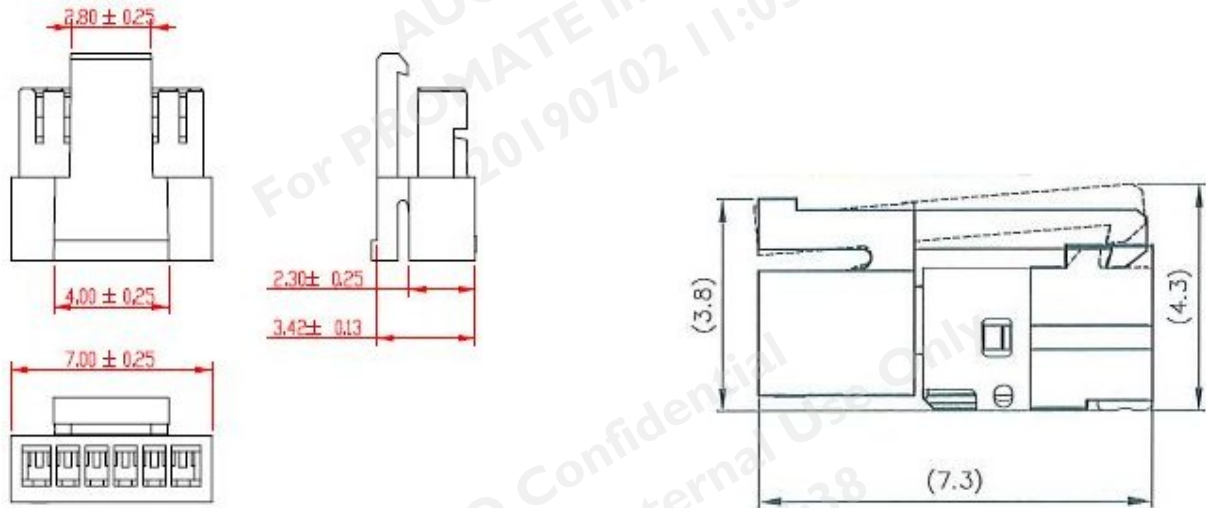

4.2.2. Connector Pin Assignment

Pin#	Symbol	Description	Remark
1	Ch1	LED Current Feedback Terminal (Channel 1)	
2	Ch2	LED Current Feedback Terminal (Channel 2)	
3	V _{SLED}	LED Power Supply Voltage Input Terminal	
4	V _{SLED}	LED Power Supply Voltage Input Terminal	
5	Ch3	LED Current Feedback Terminal (Channel 3)	
6	Ch4	LED Current Feedback Terminal (Channel 4)	

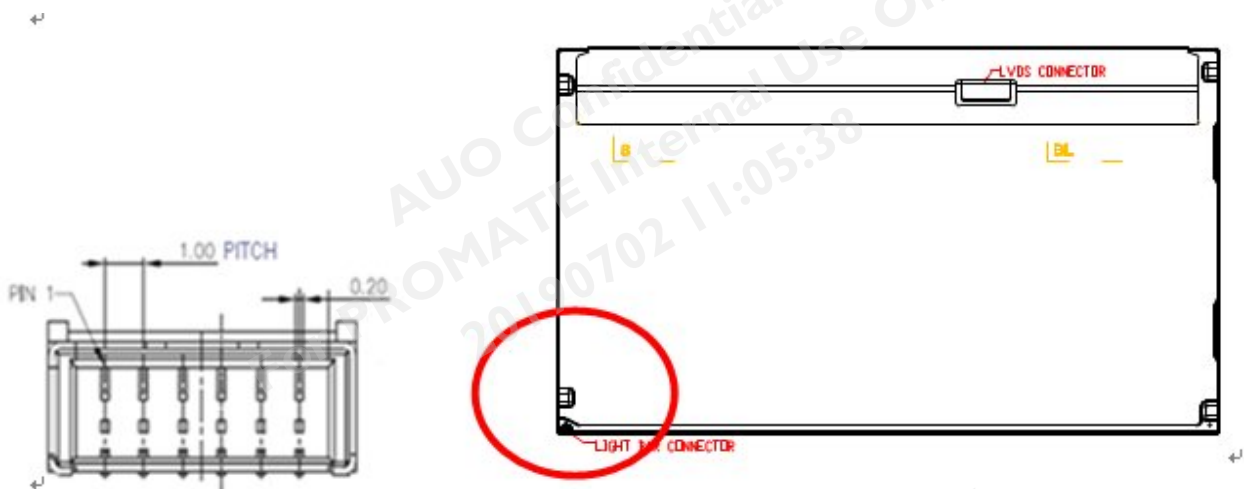

4.3. Electrical Characteristics

4.3.1. Absolute Maximum Rating

Permanent damage may occur if exceeding the following maximum rating.

(Ta=25°C)

Symbol	Description	Min	Max	Unit	Remark
Is	LED String Current	0	90	[mA]	100% duty ratio
			150	[mA]	Duty ratio ≤ 10% Pulse time=10 ms

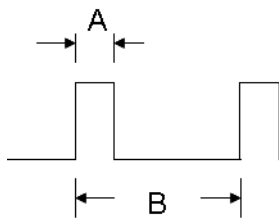

Duty ratio = (A / B) X 100% ; (A: Pulse time, B: Period)

4.3.2. Recommended Operating Condition

(Ta=25°C)

Symbol	Description	Min.	Typ.	Max.	Unit	Remark
Is	LED String Current	-	65	72	[mA]	100% duty ratio of LED chip
Vs	LED String Voltage	-	46.5	51	[Volt]	Is=65mA @ 100% duty ratio; Note 4-1, Note 4-5
ΔVs	Maximum Vs Voltage Deviation of light bar	-	-	4.5	[Volt]	Is=65mA @ 100% duty ratio; Note 4-2
P _{BLU}	LED Light Bar Power Consumption	-	12.1	13.3	[Watt]	Note 4-3
LT _{LED}	LED Life Time	30,000	-	-	[Hour]	Note 4-4
OVP	Over Voltage Protection in system board	110% Vsmax	-	-	[Volt]	Note 4-5

Note 4-1: $V_s (\text{Typ.}) = V_F (\text{Typ.}) \times \text{LED No. (one string)}$;

a. V_F : LED chip forward voltage, $V_F (\text{Min.}) = 2.8\text{V}$, $V_F (\text{Typ.}) = 3.1\text{V}$, $V_F (\text{Max.}) = 3.4\text{V}$

b. The same equation to calculate $V_s (\text{Min.})$ & $V_s (\text{Max.})$ for respective $V_F (\text{Min.})$ & $V_F (\text{Max.})$;

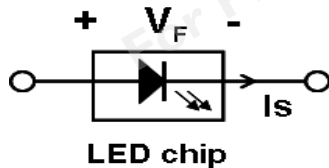

Note 4-2: $\Delta V_s (\text{Max.}) = \Delta V_F \times \text{LED No. (one string)}$;

a. ΔV_F : LED chip forward voltage deviation; (0.3 V, each Bin of LED V_F)

Note 4-3: $P_{\text{BLU}} (\text{Typ.}) = V_s (\text{Typ.}) \times I_s (\text{Typ.}) \times 4$; (4 is total String No. of LED Light bar)

$P_{\text{BLU}} (\text{Max.}) = V_s (\text{Max.}) \times I_s (\text{Typ.}) \times 4$;

Note 4-4: Definition of life time:

a. Brightness of LED becomes to 50% of its original value

b. Test condition: $I_s = 65\text{mA}$ and 25°C (Room Temperature)

Note 4-5: Recommendation for LED driver power design:

Due to there are electrical property deviation in LED & monitor set system component after long time operation. AUO strongly recommend the design value of LED driver board OVP (over voltage protection) should be 10% higher than max. value of LED string voltage (V_s) at least.

Note 4-6: AUO strongly recommend "Analog Dimming" method for backlight brightness control for Wavy Noise Free. Otherwise, recommend that Dimming Control Signal (PWM Signal) should be synchronized with Frame Frequency.

5. Reliability Test Items

AUO reliability test items are listed as following table. (*Bare Panel only*)

Items	Condition	Remark
Temperature Humidity Bias (THB)	Ta= 50°C, 80%RH, 300hours	
High Temperature Operation (HTO)	Ta= 50°C, 50%RH, 300hours	
Low Temperature Operation (LTO)	Ta= 0°C, 300hours	
High Temperature Storage (HTS)	Ta= 60°C, 300hours	
Low Temperature Storage (LTS)	Ta= -20°C, 300hours	
Vibration Test (Non-operation)	Acceleration: 1.5 Grms Wave: Random Frequency: 10 - 200 Hz Sweep: 30 Minutes each Axis (X, Y, Z)	
Shock Test (Non-operation)	Acceleration: 50 G Wave: Half-sine Active Time: 20 ms Direction: ±X, ±Y, ±Z (one time for each Axis)	
Thermal Shock Test (TST)	-20°C/30min, 60°C/30min, 100 cycles	Note 5-1
On/Off Test	On/10sec, Off/10sec, 30,000 cycles	
ESD (Electro Static Discharge)	Contact Discharge: ± 15KV, 150pF(330Ω) 1sec, 8 points, 25 times/ point.	Note 5-2
	Air Discharge: ± 15KV, 150pF(330Ω) 1sec 8 points, 25 times/ point.	
Altitude Test	Operation:18,000 ft Non-Operation:40,000 ft	

Note 5-1: a. A cycle of rapid temperature change consists of varying the temperature from -20°C to 60°C, and back again. Power is not applied during the test.
 b. After finish temperature cycling, the unit is placed in normal room ambient for at least 4 hours before power on.

Note 5-2: EN61000-4-2, ESD class B: Certain performance degradation allowed

No data lost

Self-recoverable

No hardware failures.

6. International Standard

6.1. Safety

- (1) UL 60950-1; Standard for Safety of Information Technology Equipment Including electrical Business Equipment.
- (2) IEC 60950-1; Standard for Safety of International Electrotechnical Commission
- (3) EN 60950-1; European Committee for Electrotechnical Standardization (CENELEC), EUROPEAN STANDARD for Safety of Information Technology Equipment Including Electrical Business Equipment.

6.2. EMC

- (1) ANSI C63.4 "Methods of Measurement of Radio-Noise Emissions from Low-Voltage Electrical and Electrical Equipment in the Range of 9kHz to 40GHz." American National standards Institute(ANSI), 1992
- (2) C.I.S.P.R "Limits and Methods of Measurement of Radio Interface Characteristics of Information Technology Equipment." International Special committee on Radio Interference.
- (3) EN 55022 "Limits and Methods of Measurement of Radio Interface Characteristics of Information Technology Equipment." European Committee for Electrotechnical Standardization. (CENELEC), 1998

7. Packing

7.1. Definition of Label

A. Panel Label:

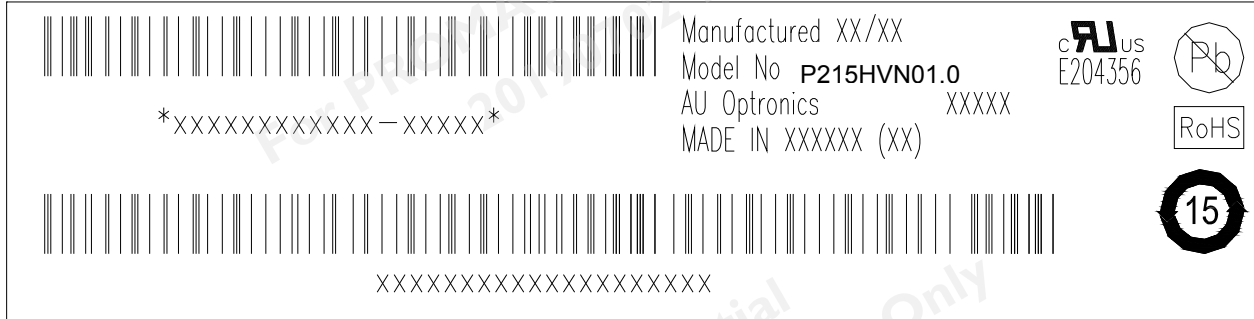

Green mark description

(1) For Pb Free Product, AUO will add  for identification.

(2) For RoHs compatible products, AUO will add  for identification.

Note: The green Mark will be present only when the green documents have been ready by AUO internal green team. (definition of green design follows the AUO green design checklist.)

B. Carton Label:

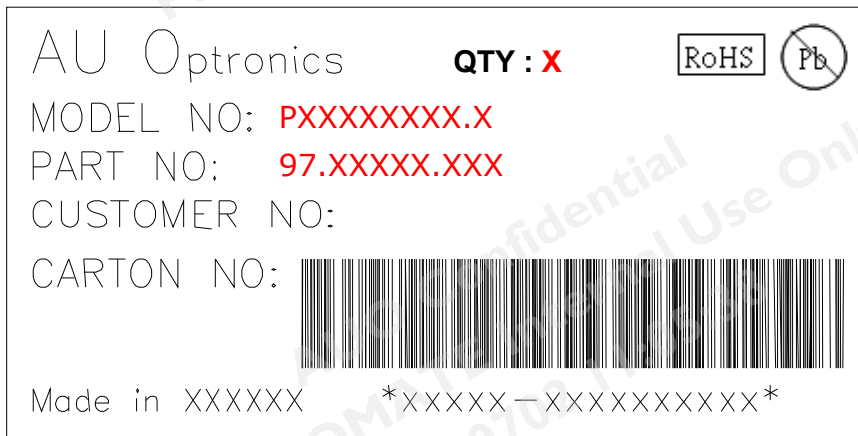

7.2. Packing Methods

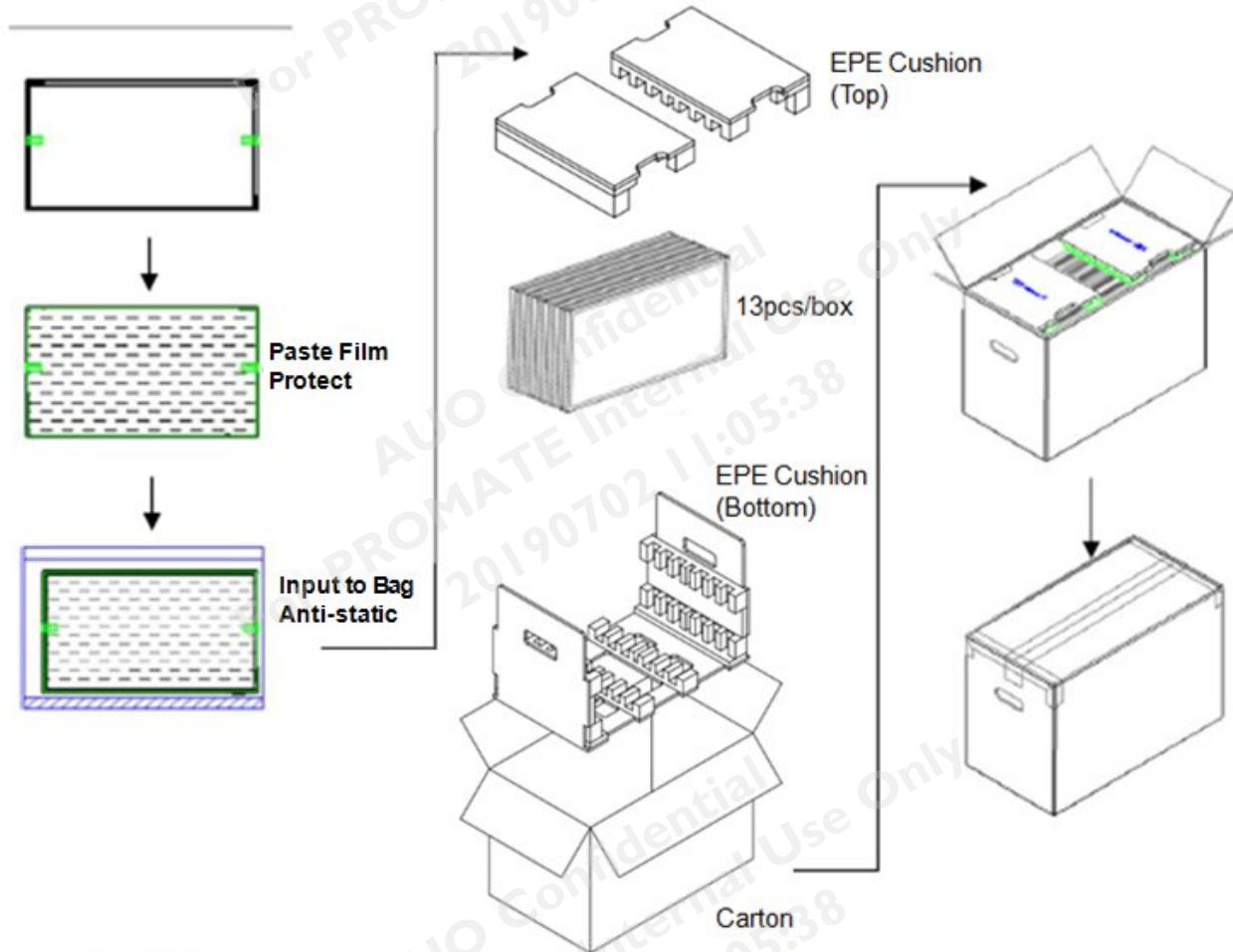

7.3 Pallet and Shipment Information

Item	Specification			Remark
	Q'ty	Dimension	Weight(kg)	
Panel	1	495.6(H)mm ×292.2 (V)mm ×10.6(D)mm	1.67	Note 1
Cushion	1	-	0.55	Note 1
Box	1	565(L)mm x 345(W)mm x 375(H)mm	1.40	without Panel Note 1
Packing Box	13pcs/Box	565(L)mm x 345(W)mm x 375(H)mm	23.66	with panel & Box & cushion Note 1
Pallet	1	1150(L)mm x 1070(W)mm x 132(H)mm	14.2	Note 1
Pallet after Packing	18 boxes/pallet	1150(L)mm x 1070(W)mm x 1257(H)mm	495	Note 1

Note 1: Estimated value which is subject to change based on real measured data.

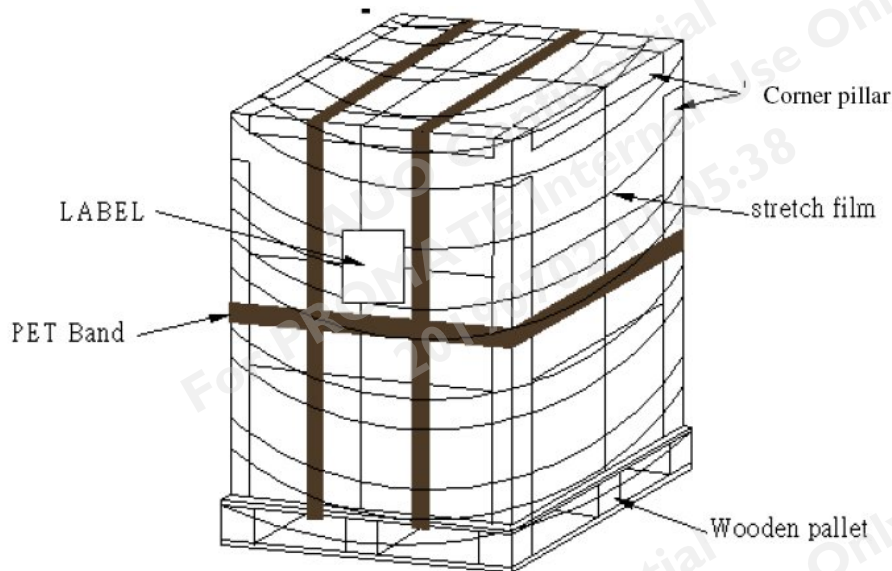

Single pallet stack Illustration

8. Precautions

Please pay attention to the followings when you use this TFT LCD module.

8.1. Mounting Precautions

- (1) You must mount a module using holes arranged in four corners or four sides.
- (2) You should consider the mounting structure so that uneven force (ex. twisted stress) is not applied to module. And the case on which a module is mounted should have sufficient strength so that external force is not transmitted directly to the module.
- (3) Please attach the surface transparent protective plate to the surface in order to protect the polarizer. Transparent protective plate should have sufficient strength in order to resist external force.
- (4) You should adopt radiation structure to satisfy the temperature specification.
- (5) Acetic acid type and chlorine type materials for the cover case are not desirable because the former generates corrosive gas of attacking the polarizer at high temperature and the latter cause circuit broken by electro-chemical reaction.
- (6) Do not touch, push or rub the exposed polarizer with glass, tweezers or anything harder than HB pencil lead. And please do not rub with dust clothes with chemical treatment. Do not touch the surface of polarizer for bare hand or greasy cloth. (Some cosmetics are detrimental to the polarizer.)
- (7) When the surface becomes dusty, please wipe gently with absorbent cotton or other soft materials like chamois soaks with petroleum benzene. Normal-hexane is recommended for cleaning the adhesives used to attach front/ rear polarizer. Do not use acetone, toluene and alcohol because they cause chemical damage to the polarizer.
- (8) Wipe off saliva or water drops as soon as possible. Their long time contact with polarizer causes deformations and color fading.
- (9) Do not open the case because inside circuits do not have sufficient strength.

8.2. Operating Precautions

- (1) The spike noise causes the mis-operation of circuits. It should be lower than following voltage:
 $V = \pm 200\text{mV}$ (Over and under shoot voltage)
- (2) Response time depends on the temperature. (In lower temperature, it becomes longer..)
- (3) Brightness depends on the temperature. (In lower temperature, it may become lower.) And in lower temperature, response time (required time that brightness is stable after turned on) becomes longer.
- (4) Be careful for condensation at sudden temperature change. Condensation makes damage to polarizer or electrical contacted parts. And after fading condensation, smear or spot will occur.
- (5) When fixed patterns are displayed for a long time, remnant image is likely to occur.
- (6) Module has high frequency circuits. Sufficient suppression to the electromagnetic interference shall be done by system manufacturers. Grounding and shielding methods may be important to minimize the interface.

8.3. Operating Condition for Public Information Display

The device listed in the product specification is designed and manufactured for PID (Public Information

Display) application. To optimize module's lifetime and function, below operating usages are required.

(1) Normal operating condition

- A. Operating temperature: -10~50°C
- B. Operating humidity: 10~90%
- C. Display pattern: dynamic pattern (Real display).

Note) Long-term static display would cause image sticking.

(2) Operation usage to protect against image sticking due to long-term static display.

- A. Suitable operating time: 20 hours or less a day.
- B. Liquid Crystal refresh time is required. Cycling display between 5 minutes' information (static) display and 10 seconds' moving image.
- C. Periodically change background and character (image) color.
- D. Avoid combination of background and character with large different luminance.

(3) Periodically adopt one of the following actions after long time display.

- A. Running the screen saver (motion picture or black pattern)
- B. Power off the system for a while

(4) LCD system is required to place in well-ventilated environment. Adapting active cooling system is highly recommended.

(5) Product reliability and functions are only guaranteed when the product is used under right operation usages. If product will be used in extreme conditions, such as high temperature/ humidity, display stationary patterns, or long operation time etc..., it is strongly recommended to contact AUO for filed application engineering advice. Otherwise, its reliability and function may not be guaranteed. Extreme conditions are commonly found at airports, transit stations, banks, stock market and controlling systems.

8.4. Electrostatic Discharge Control

Since a module is composed of electronic circuits, it is not strong to electrostatic discharge. Make certain that treatment persons are connected to ground through wristband etc. And don't touch interface pin directly.

8.5. Precautions for Strong Light Exposure

Strong light exposure causes degradation of polarizer and color filter.

8.6. Storage

When storing modules as spares for a long time, the following precautions are necessary.

- (1) Store them in a dark place. Do not expose the module to sunlight or fluorescent light. Keep the temperature between 5°C and 35°C at normal humidity.
- (2) The polarizer surface should not come in contact with any other object. It is recommended that they be stored in the container in which they were shipped.

- (3) Storage condition is guaranteed under packing conditions.
- (4) The phase transition of Liquid Crystal in the condition of the low or high storage temperature will be recovered when the LCD module returns to the normal condition.

8.7. Handling Precautions for Protection Film

- (1) The protection film is attached to the bezel with a small masking tape. When the protection film is peeled off, static electricity is generated between the film and polarizer. This should be peeled off slowly and carefully by people who are electrically grounded and with well ion-blown equipment or in such a condition, etc.
- (2) When the module with protection film attached is stored for a long time, sometimes there remains a very small amount of glue still on the bezel after the protection film is peeled off.
- (3) You can remove the glue easily. When the glue remains on the bezel or its vestige is recognized, please wipe them off with absorbent cotton waste or other soft material like chamois soaked with normal-hexane.